

SINCE 1975

EHWA

CARBIDE ENDMILLS & DRILLS

STANDARD TO SPECIAL SERIES



EHWA



"Yes we are"

EHWA



Ehwa Diamond Carbide Endmill & Drill Series

ENDMILLS



CARBIDE ENDMILLS

World class special order made service provider Ehwa's first move to global standard users.

You can now meet Ehwa's global standard line-up for your productivity improvement.



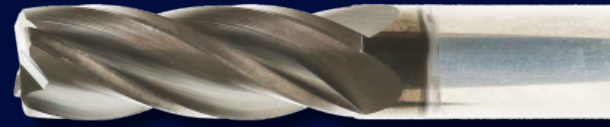

Ehwa Diamond Carbide Endmill & Drill Series

ENDMILLS

EHWA'S ENDMILL CODE SYSTEM

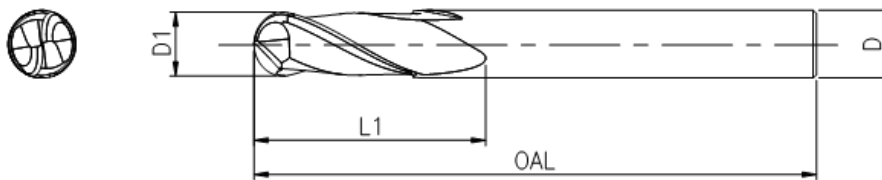
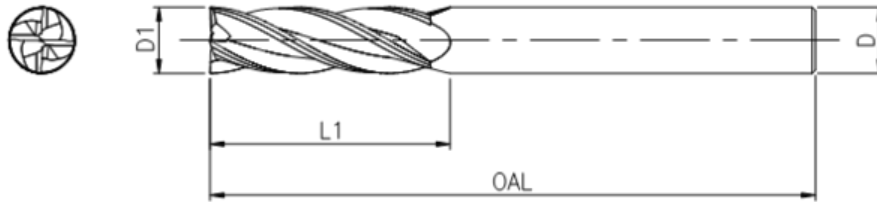

EWHA
TUNGSTEN CARBIDE
CERAMIC

DIAMETER1

CUTTING LENGTH

NO. OF FLUTE

ET EF 04 04 - 050 100 - 4F T

ENDMILL TYPE

DIAMETER2

OVERALL LENGTH

COATING TYPE

F : FLAT ENDMILL
B : BALL ENDMILL
S : SQUARE ENDMILL
TB : TAPER BALL ENDMILL

TI : TiN
AC : ALCrN
TS : TiSiN
DL : DLC
DM : DIAMOND
H : HE

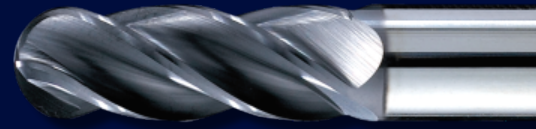

Ehwa Diamond Carbide Endmill & Drill Series

ENDMILLS

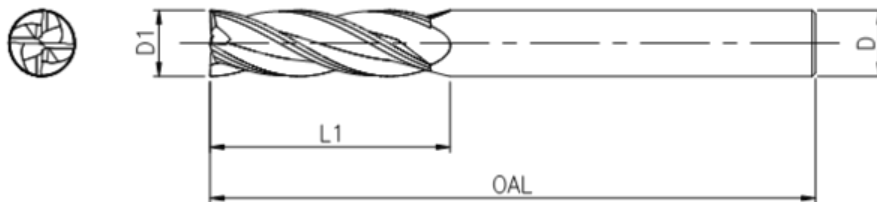

SQAURE FLAT ENDMILLS - AT COATED

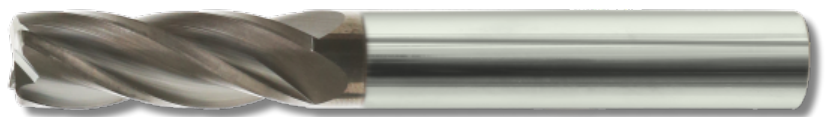

Product Code	TYPE	D1	D	L1	OAL	Z	COATING
ETEF0606-30-60-4-AT	EF	6	6	30	60	4	AT
ETEF0808-30-80-4-AT	EF	8	8	30	80	4	AT
ETEF1010-30-80-6-AT	EF	10	10	30	80	6	AT
ETEF1212-30-80-6-AT	EF	12	12	30	80	6	AT

SQAURE FLAT ENDMILLS - TS COATED



Product Code	TYPE	D1	D	L1	OAL	Z	COATING
ETEF0606-30-60-4-TS	EF	6	6	30	60	4	TS
ETEF0808-30-80-4-TS	EF	8	8	30	80	4	TS
ETEF1010-30-80-6-TS	EF	10	10	30	80	6	TS
ETEF1212-30-80-6-TS	EF	12	12	30	80	6	TS



Ehwa Diamond Carbide Endmill & Drill Series

ENDMILLS

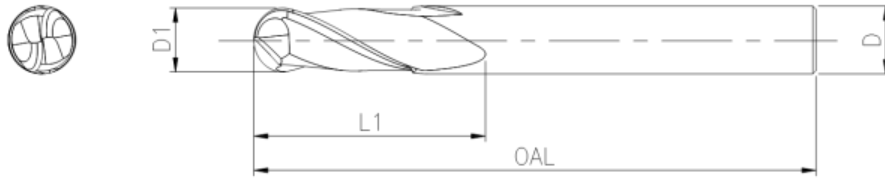

BALL ENDMILLS



Product Code	TYPE	D1	D	L1	OAL	Z	COATING
ETEB0606-30-60-4	EB	6	6	30	60	4	-
ETEB0808-30-80-4	EB	8	8	30	80	4	-
ETEB1010-30-80-4	EB	10	10	30	80	4	-
ETEB1212-30-80-4	EB	12	12	30	80	4	-

TAPER BALL ENDMILLS



Product Code	TYPE	D1	D	L1	OAL	Z	COATING
ETTB0606-30-60-4	TB	6	6	30	60	4	-
ETTB0808-30-80-4	TB	8	8	30	80	4	-
ETTB1010-30-80-4	TB	10	10	30	80	4	-
ETTB1212-30-80-4	TB	12	12	30	80	4	-



Ehwa Diamond Carbide Endmill & Drill Series

DRILLS

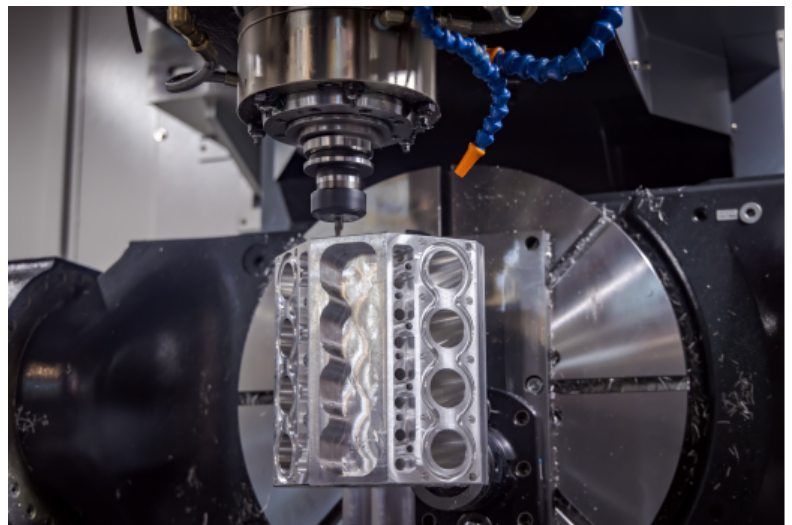

CARBIDE DRILLS

Ehwa's first Global Standard Drill Series is a great choice for your excellent hole precision machining process. Ehwa's wide range of solid carbide drill include various applications for such as automotive, aerospace and semi-conductor industries. Please contact visit our website for further information.

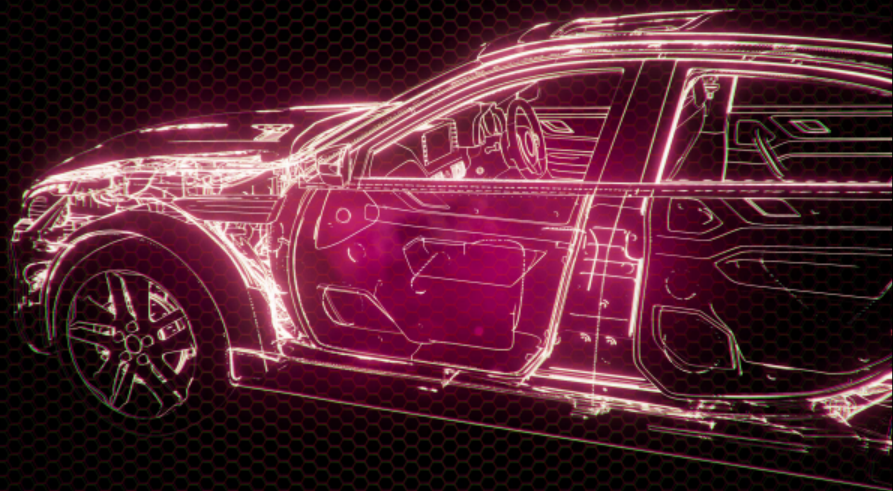

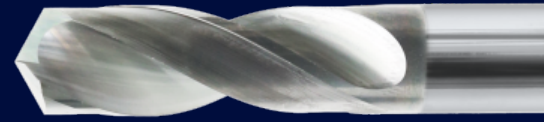

Ehwa Diamond Carbide Endmill & Drill Series

DRILLS

EHWA DIAMOND - DRILL CODE SYSTEM

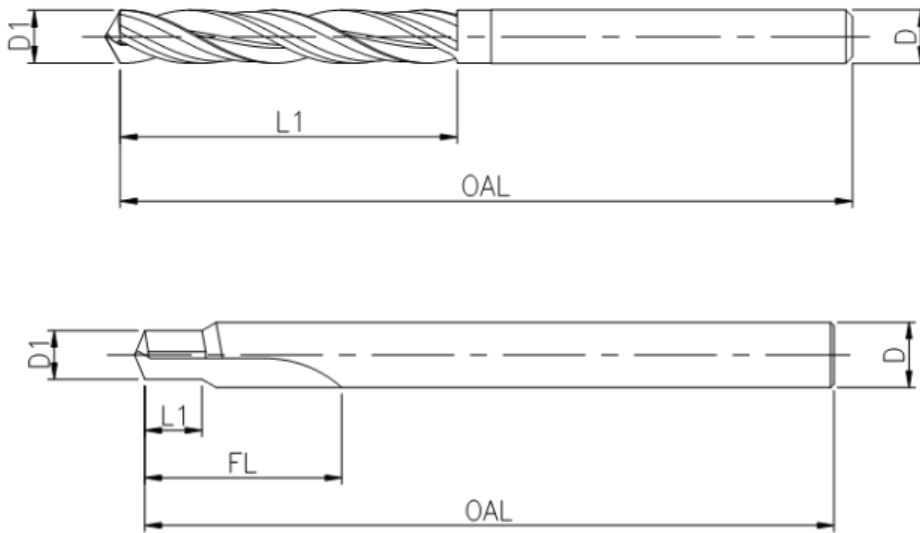

EHWA
TUNGSTEN CARBIDE

DIAMETER1

CUTTING LENGTH

OVERAL LENGTH

COATING TYPE

- TI : TiN
- AC : ALCrN
- TS : TiSiN
- DL : DLC
- DM : DIAMOND

ET DB 12 16 030 060 100 2F AT

DRILL TYPE

DIAMETER2

NECK LENGTH

NO. OF FLUTE

STEP DRILL
BURNISHING DRILL





Ehwa Diamond Carbide Endmill & Drill Series

DRILLS

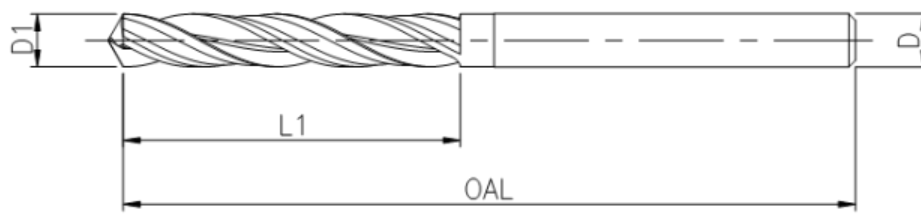

DRILLS

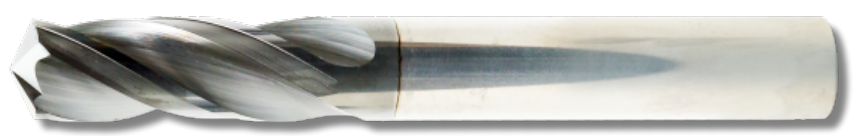

Product Code	TYPE	D1	D	L1	OAL	Z	COATING
ETDH0606-30-60-2-AT	DH	6	6	30	60	2	AT
ETDH0808-30-80-4-AT	DH	8	8	30	80	2	AT
ETDH1010-30-80-4-AT	DH	10	10	30	80	2	AT
ETDH1212-30-80-4-AT	DH	12	12	30	80	2	AT

DRILLS



Product Code	TYPE	D1	D	L1	OAL	Z	COATING
ETDH0606-30-60-2-TS	DH	6	6	30	60	2	TS
ETDH0808-30-80-4-TS	DH	8	8	30	80	2	TS
ETDH1010-30-80-4-TS	DH	10	10	30	80	2	TS
ETDH1212-30-80-4-TS	DH	12	12	30	80	2	TS



Ehwa Diamond Carbide Endmill & Drill Series

DRILLS



BURNISHING DRILLS - AT COATED



Product Code	TYPE	D1	D	L1	OAL	Z	COATING
ETDB0606-1530-60-2-AT	DB	6	6	15-30	60	2	AT
ETDB0808-1530-80-2-AT	DB	8	8	15-30	80	2	AT
ETDB1010-1530-80-2-AT	DB	10	10	15-30	80	2	AT
ETDB1212-1530-80-2-AT	DB	12	12	15-30	80	2	AT

BURNISHING DRILLS

Product Code	TYPE	D1	D	L1	OAL	Z	COATING
ETDB0606-1530-60-2	DB	6	6	15-30	60	2	-
ETDB0808-1530-80-2	DB	8	8	15-30	80	2	-
ETDB1010-1530-80-2	DB	10	10	15-30	80	2	-
ETDB1212-1530-80-2	DB	12	12	15-30	80	2	-

EHWA DIAMOND INDUSTRIAL, THE FIRST MOVE



EHWA



EHWA

::: Headquarters : 374, Nambu-daero Osan-si Gyeonggi-do, South Korea 18145]

Phone: +82-31-370-9000 Fax : +82-31-372-2336 :::

::: Dongtan factory : 10, Dongtansandan 3-gil Dongtan-myeon Hwaseong-si Gyeonggi-do, South Korea 18487]

Phone: +82-31 370 0500 Fax: +82-31 370 0500 :::